

VOSCH

FOREST
PIONEER

Precision for complex logging



1 650-7T VC

POWER WITH TOTAL CONTROL

Laspinzascon sierra VOSCH1650-7TVCy1950-7TVC
They are designed for 15-30 ton excavators and controlled felling operations that require precision.

They offer a cutting capacity of up to 800 mm, a maximum opening of 1790/1900 mm and a closing force of up to 76 kN.

VC (Vosch Control) technology guarantees unlimited adjustments, simplified assembly, and increased working speed thanks to the integrated hydraulic valve.



1 950-7T VC



Measures

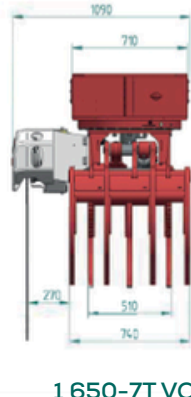
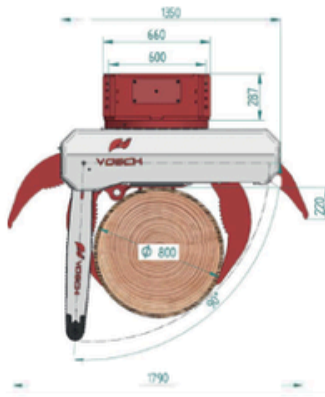

1 650-7T VC

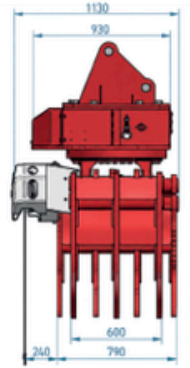
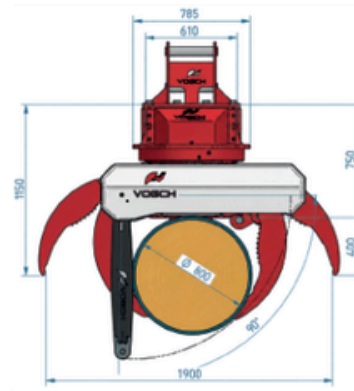

1 950-7T VC

Technical characteristics	1 650-7T VC	1 950-7T VC
Weight with saw unit (kg)	1.150	1.420
Base machine weight (t)	15-21	18-30
Maximum working pressure (bars)	350	350
Maximum rotation pressure (bars)	120	120
Clamp flow rate (l/min) Rotation	220	220
flow rate (l/min) Maximum	60-80	-
opening (mm)	1.790	1.900
Maximum cutting diameter (mm)	800	800
Saw motor (cc) Cutting blade	30	30
(in/cm)	40" / 101	40" / 101
Chain size Closing	3/4"	3/4"
force (kN) Rotation	55	76
torque (kN.m) Arm	58	60
type	7 bras	7 bras
Hydraulic lines	P.T. drain / CANbus	P.T. drain / CANbus
Controls / Commands	Multifunction joystick and	
Base machine type	screen for hydraulic excavator	



SOLICITE
PRESUPUESTO
SIN COMPROMISO



+34 943 63 64 82

info@forestpioneer.com

