

ROTATOR GV 12

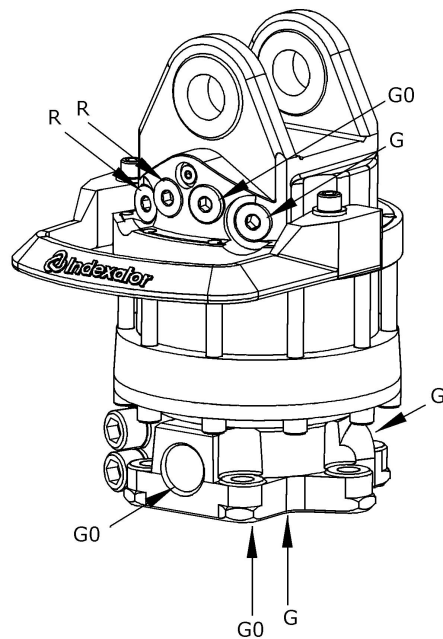
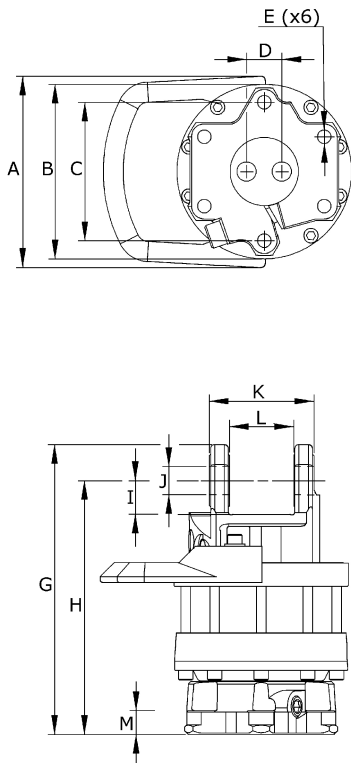

Technical data

Part no	5112 049
Dimensional drawing	2000 503
Hydraulic circuit	2100 002
Rotation	unlimited
Weight	54 kg
Max axial load, static	100 kN
Max axial load dynamic	50 kN
Torque at 25 MPa	2 200 Nm

Measure specification

	mm
A	239
B	Ø218
C	Ø173
D	44
E	Ø17
G	362
H	317
I	42
J	Ø35*
K	131
L	80,5*
M	30

Function	Max working pressure	Rec oilflow
R = Rotation	25 MPa	25 l/min
GO = Grapple open	25 MPa	*
G = Grapple close	25 MPa	*

Connections¹

Upper	G 1/2
Lower	G 3/4

¹ We supply adapter sets for alternative connections

* For more technical information about installation and hydraulic connections, we refer to dimensional drawing and hydraulic circuit as specified above. These documents can be ordered at sales@indexator.se